

NoSwet® Knapp™ Hinged Knee Orthosis Range of Motion 12in

7656ROM

Warnings and Instructions: Review carefully, proper application is required

⚠ Warning: This device will not prevent or eliminate risk of injury. Do Not Overtighten. If swelling, pain, skin irritation, or an unusual reaction occurs, discontinue use immediately and consult your medical professional. This device should not be worn by persons with known allergies to neoprene. Care: Hand wash using mild soap. Rinse thoroughly. Air dry only. Do not tumble dry.

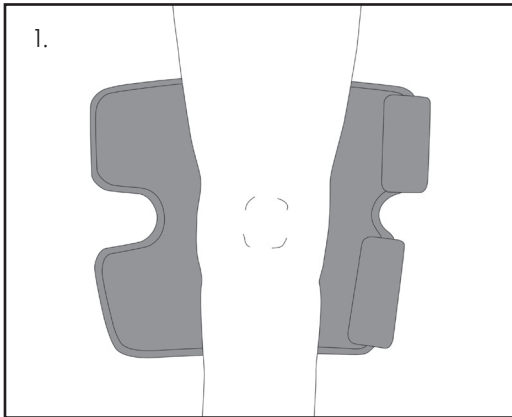

1. Center brace on back of leg.

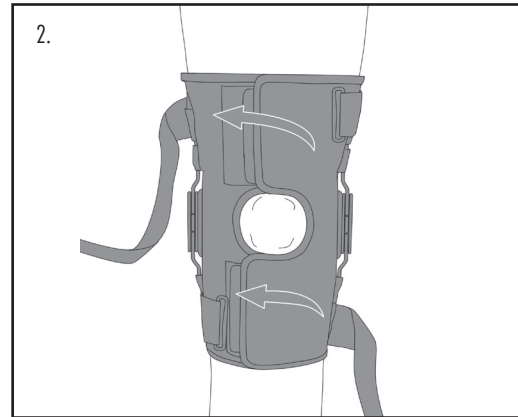

2. Pull upper and lower flaps and fasten.

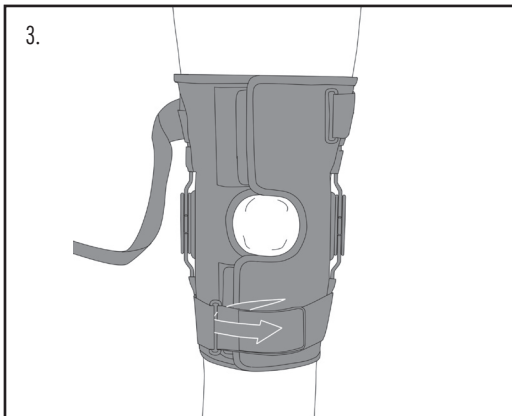

3. Pull lower strap through loop lock and fasten.

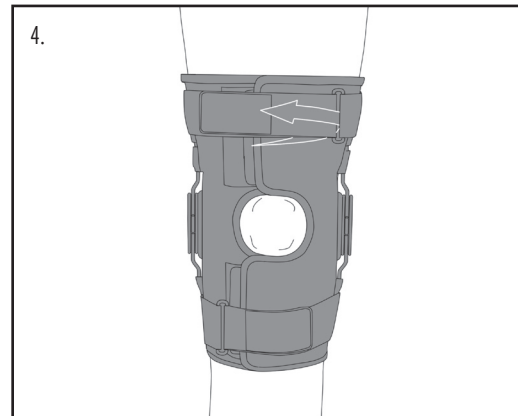

4. Pull upper strap through loop lock and fasten.

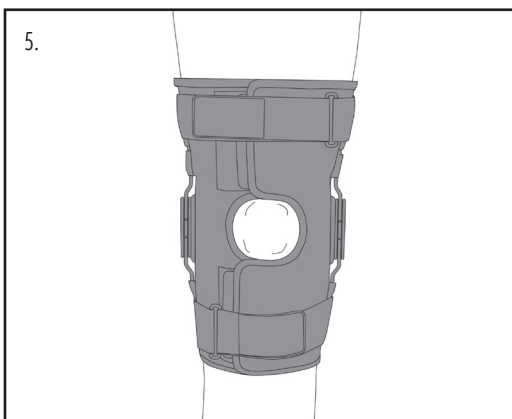

5. Finished application.

Range of Motion Hinge Stop Application

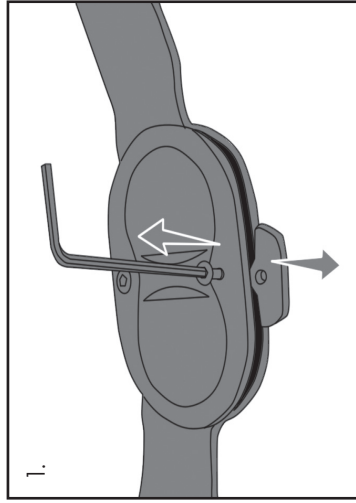

1. Use the included hex wrench to remove the existing hinge stops by removing the screws.

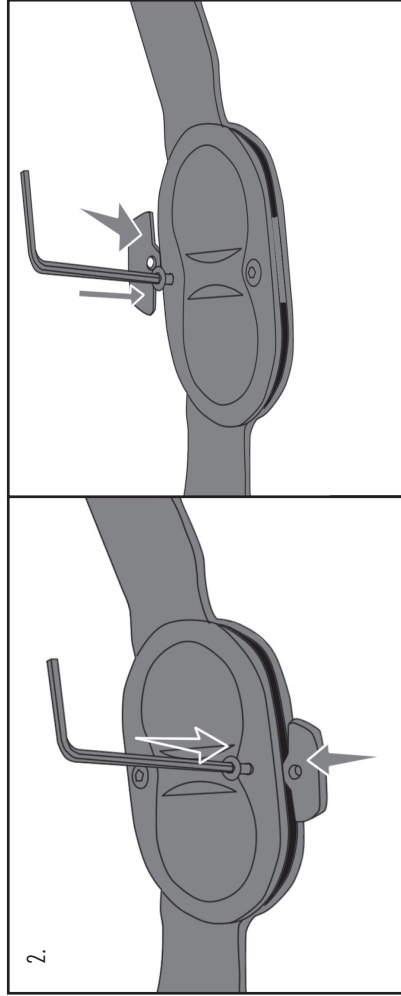

2. Choose the hinge stops with the desired degrees of extension and flexion. Install the extension stop on the extension stop side of the hinge, and the flexion stop on the flexion stop side of the hinge. Tighten the screws so they are secure but not tight. If the hinges do not move freely loosen the screws.

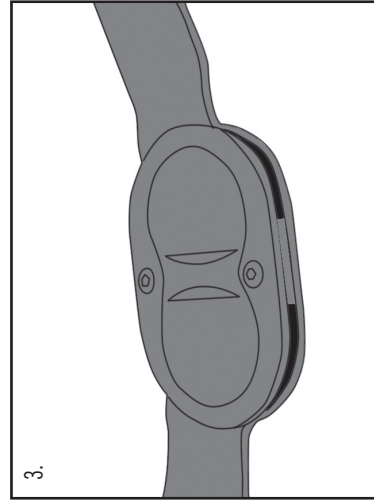

3. Completed application.
Both medial and lateral hinges must be set to the same extension and flexion.

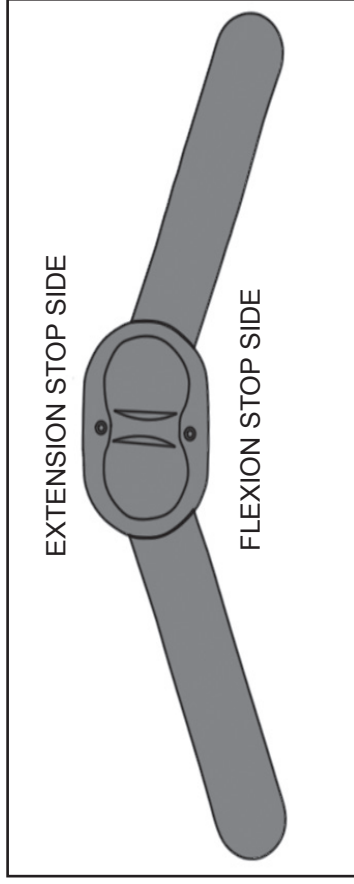

Each stop has two numbers on the front for the degree of flexion (F) or the degree of extension (E) based on which side of the hinge the stop is used.

HINGE STOP FINDER

Hinge stops shown below are included for Flexion (F) and Extension (E)
Place hinge stop on chart to verify size

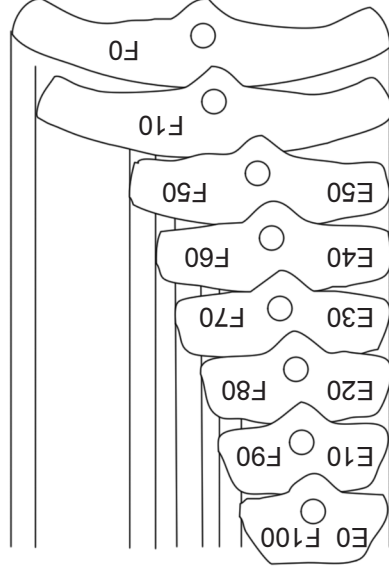

MDSS GmbH, Schiffgraben 41
30175 Hannover, Germany

1185 E Main St., Santa Paula, California 93060
California: 800-221-5465, National: 800-654-3241
International: 805-525-4244, fax: 805-933-2348
U.S. fax: 800-559-5975, www.hely-weber.com



Rev B 4/16